



ELECTRIC REACH TRUCK (STAND ON)

前移式叉车 (站驾式)

MF12/15/15D

MF20/25/30

起升高度 5m-8m Lifting height



+

转弯半径小, 转向灵活

MF前移式叉车 – 操作灵活, 性能强大

MF FORWARD FORKLIFT - FLEXIBLE OPERATION AND POWERFUL PERFORMANCE

前移式叉车一直在全球各地的仓库中提供可靠的服务和性能。特别是在狭窄的条件下, MF系列电动前移式叉车凭借其紧凑的结构和出色的提升能力发挥其强大性能。

Forward forklift has been providing reliable service and performance in warehouses around the world. Especially in narrow conditions, MF series electric forward forklift with its compact structure and excellent lifting capacity to play its powerful performance.



舒适美观的设计

全新设计的控制踏板和符合人体工学的防震踏板, 确保了驾驶的舒适性;
Comfortable and beautiful design
The newly designed control pedal and ergonomic shockproof pedal ensure the driving comfort;



货叉倾斜

可倾斜货叉可倾斜的货叉使托盘堆垛工作更加简易安全, 同时货叉与托盘货架分开也更加简单, 有效防止货物从货叉滑落。

Fork tilt
The tiltable fork makes the palletizing work easier and safer. At the same time, the separation of the fork and the pallet shelf is simpler, which effectively prevents the goods from falling from the fork.



门架系统

门架具有前移功能, 在不移动车身的情况下实现货物的存放更加舒适安全, 高质量的槽钢保证了车辆的负载能力;

Gantry system
The gantry has the function of moving forward, which makes the storage of goods more comfortable and safe without moving the body. The high-quality channel steel ensures the load capacity of the vehicle;



侧拉电池

侧拉电池设计, 电池充电更换更加快捷方便。

Side pull battery
Side pull battery design makes battery charging and replacement more convenient.



Small turning radius, flexible turning



高性能HIGH PERFORMANCE

交流驱动系统, 美国品牌交流电机提供强劲动力; 控制更精确, 运行更平稳, 高强度立式变速箱, 超长使用寿命经过多层检测测试的油泵、油缸及管路, 保证了液压系统高可靠;

AC drive system, American brand AC motor provides strong power; more accurate control, more stable operation, high-strength vertical gearbox, ultra long working life after multi-layer testing of oil pump, oil cylinder and pipeline, ensuring the high reliability of the hydraulic system;

质量可靠的美国AMP防水接插件及电器件, 所有电线、电缆均有可靠的保护和固定, 大大降低了电器故障; 强度承载轮设计, 确保整车稳定性; 高强度架槽钢, 高抗弯性能提高了整体门架强度。

Reliable quality American amp waterproof connector and electrical parts, all wires and cables are reliably protected and fixed, greatly reducing electrical failure; Strength bearing wheel design to ensure vehicle stability; High strength channel steel and high bending resistance improve the strength of the whole gantry.

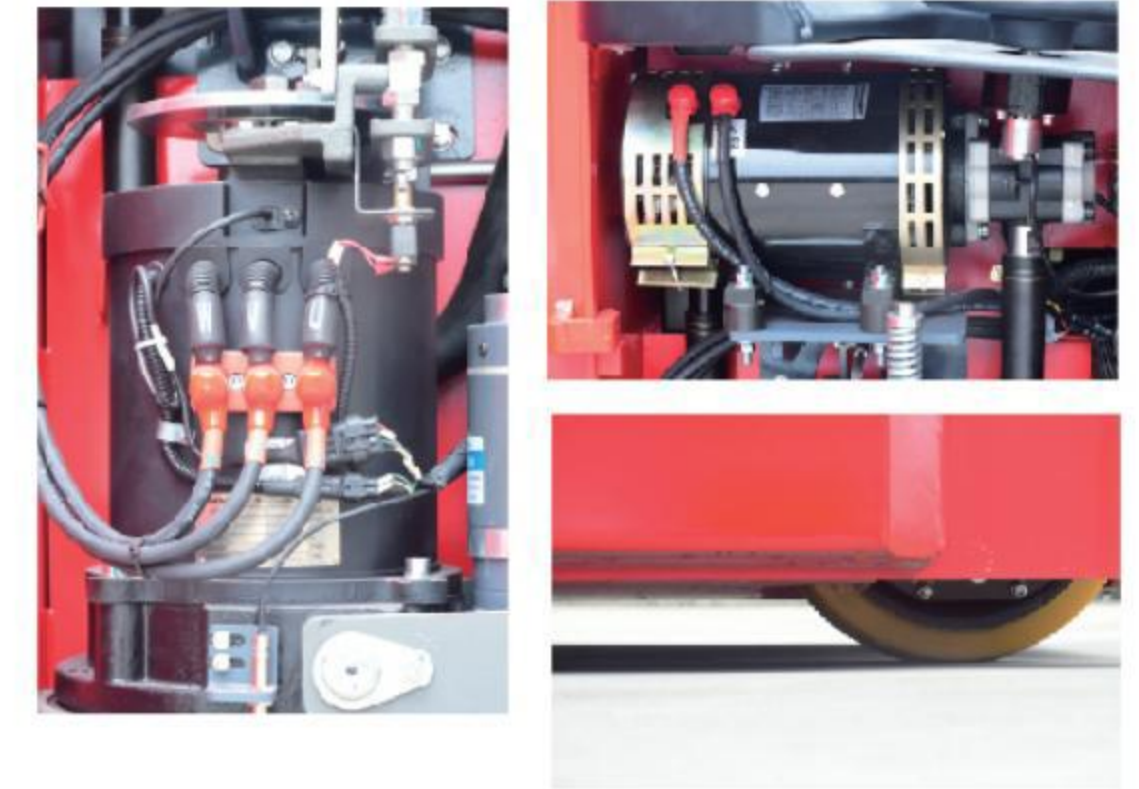

易操作EASY OPERATION

充分考虑人机工程的操控台, 各功能按钮方便轻松操作; 驾驶位置设置靠垫, 驾驶更舒适;

Fully considering the control console of human-machine engineering, the buttons of various functions are easy to operate: The driving position is equipped with cushions to make driving more comfortable;

更安全MORE SAFE

弯道自动减速功能, 行驶更安全。
紧急断电开关, 在操作失控时可轻松切断所有电源, 避免紧急事故;
防滑制动功能, 使车子在失控或者斜坡行驶时, 防止其下滑;
强壮的护顶架设计, 作业更安全;

Automatic deceleration function in curve, safer driving
The emergency power-off switch can easily cut off all power supplies when the operation is out of control to avoid emergency accidents:
Anti slip braking function, to prevent the car from sliding when it is out of control or driving on a slope;
Strong roof support design, safer operation;



标准/Standard					
1.2 型号 Model		MF12	MF12SQ	MF15D	MF15DSQ
1.3 动力类型 Power type		蓄电池 Battery	蓄电池 Battery	蓄电池 Battery	蓄电池 Battery
1.4 驾驶方式 Driving mode		站驾式 Station driving type	站驾式 Station driving type	站驾式 Station driving type	站驾式 Station driving type
1.5 额定载荷 Rated load	Q (kg)	1200	1500	1500	1500
1.6 载荷中心距 Load center distance	C (mm)	500	500	500	500
1.7 前悬距 Front suspension distance	x (mm)	140	140	140	140
1.8 轴距 Wheelbase	y (mm)	1270	1270	1345	1345
重量/Weight					
2.1 整车重量 (含电池) Vehicle weight (Containing battery)	kg	2000	2250	2100	2350
2.2 空载时的桥负荷, 驱动侧/承重侧 Bridge load at no load, drive side / load side	kg	1440/560	1550/700	/	/
2.3 满载时的桥负荷, 货叉前移, 驱动侧/承重侧 Full load bridge load, fork forward, drive side / load side	kg	570/2630	580/2870	/	/
2.4 满载时的桥负荷, 货叉收回, 驱动侧/承重侧 Bridge load with full load, fork retracted, drive side / load side	kg	1420/1780	1500/1950	/	/
轮胎/Tyre					
3.1 轮胎类型, 驱动侧/承重侧 Tire type, drive / load side		聚氨酯 PU	聚氨酯 PU	聚氨酯 PU	聚氨酯 PU
3.2 轮胎尺寸, 承重侧 Tire size, load side	mm	Φ 210 × 85	Φ 210 × 85	Φ 210 × 85	Φ 210 × 85
3.3 轮胎尺寸, 驱动侧 Tire size, drive side	mm	Φ 230 × 110	Φ 230 × 110	Φ 230 × 110	Φ 230 × 110
3.4 稳定轮尺寸 Size of stabilizing wheel	mm	Φ 180 × 76	Φ 180 × 76	Φ 180 × 76	Φ 180 × 76
3.5 车轮数量, 前/后(x-驱动轮) Number of wheels, front / rear (x=drive wheel)		2/1 x+2	2/1 x+2	2/1 x+2	2/1 x+2
3.6 轮距, 驱动侧 Track width, drive side	b10 (mm)	615	615	615	615
3.7 轮距, 承重侧 Track width, load side	b11 (mm)	999	999	999	999
尺寸/Size					
4.1 货叉倾斜范围, 前/后 Fork tilt range, front / rear	α / β (°)	3/5	3/5	3/5	3/5
4.2 门架闭合高度 Gantry closing height	h1 (mm)	2080	2080	2080	2080
4.3 自由起升高度 Free lifting height	h2 (mm)	/	1480	/	1480
4.4 起升高度 Lifting height	h3 (mm)	3000	4500	3000	4500
4.5 起升时门架最大高度 (含挡货架) Maximum height of gantry during lifting (including retaining rack)	h4 (mm)	3960	5460	3960	5460
4.6 护顶架高度 Height of roof support	h6 (mm)	2250	2250	2250	2250
4.7 站板高度 Station height	h7 (mm)	300	300	300	300
4.8 整车长度 Vehicle length	l1 (mm)	2078	2106	2078	2106
4.9 整车宽度 Vehicle width	b1/b2 (mm)	1090 / 1000	1090 / 1000	1090 / 1000	1090 / 1000
4.10 货叉尺寸 Fork size	l/e/s (mm)	1070 / 100 / 35	1070 / 100 / 35	1070 / 100 / 35	1070 / 100 / 35
4.11 挡货架宽度 Shelf width	b3 (mm)	1088	1088	1088	1088
4.12 货叉外悬距 Fork outside distance	b5 (mm)	222-750	222-750	222-750	222-750
4.13 支腿内悬距 Inner distance of Outrigger	b4 (mm)	822	822	822	822
4.14 前移距离 Fork rake	l4 (mm)	600	570	690	660
4.15 门架离地间隙 Clearance between gantry and ground	m1 (mm)	80	80	80	80
4.16 直角堆垛通道宽度 (托盘1000x1200) 500mm 载荷中心 Right angle stacking channel width (tray 1000x1200) 500mm load center	Ast (mm)	2502	2521	2532	2550
4.17 直角堆垛通道宽度 (托盘800x1200) Right angle stacking channel width (tray 800x1200) 600mm load center	Ast (mm)	2537	2561	2547	2571
4.18 转弯半径 Turning radius	Wa (mm)	1492	1492	1580	1580
性能/Performance					
5.1 行驶速度, 满/空载 Travel speed, full / empty	km / h	7/8	7/8	7/8	7/8
5.2 起升速度, 满/空载 Travel speed, full / empty	mm / s	150 / 190	130 / 190	150 / 190	100 / 190
5.3 下降速度, 满/空载 Descent speed, full / empty	mm / s	190 / 170	170 / 130	190 / 170	170 / 130
5.4 最大爬坡能力, 满/空载 Maximum climbing capacity, full / empty	%(tan θ)	≤10	≤10	≤8/≤10	≤8/≤10
5.5 制动方式 Braking mode		机械式 Mechanical	机械式 Mechanical	机械式 Mechanical	机械式 Mechanical
驱动/Drive					
6.1 驱动电机功率 Drive motor power	kw	2.3	2.3	2.3	2.3
6.2 起升电机功率 Power of lifting motor	kw	3.5	3.5	3.5	3.5
6.3 蓄电池, 电压/额定容量 Battery, voltage / rated capacity	V/Ah	24/350	24/350	24/420	24/420
6.4 电池重量 Battery weight	kg	300	300	335	335
6.5 转向系统 steering system		纯电转向 EPS	纯电转向 EPS	纯电转向 EPS	纯电转向 EPS
其它/Other					
7.1 电池更换方式 Battery replacement		侧拉式 Side pull type	侧拉式 Side pull type	侧拉式 Side pull type	侧拉式 Side pull type
7.2 锂电池选项, 电压/额定容量 Battery option, voltage / rated	V/Ah	24/300	24/300	24/300	24/300

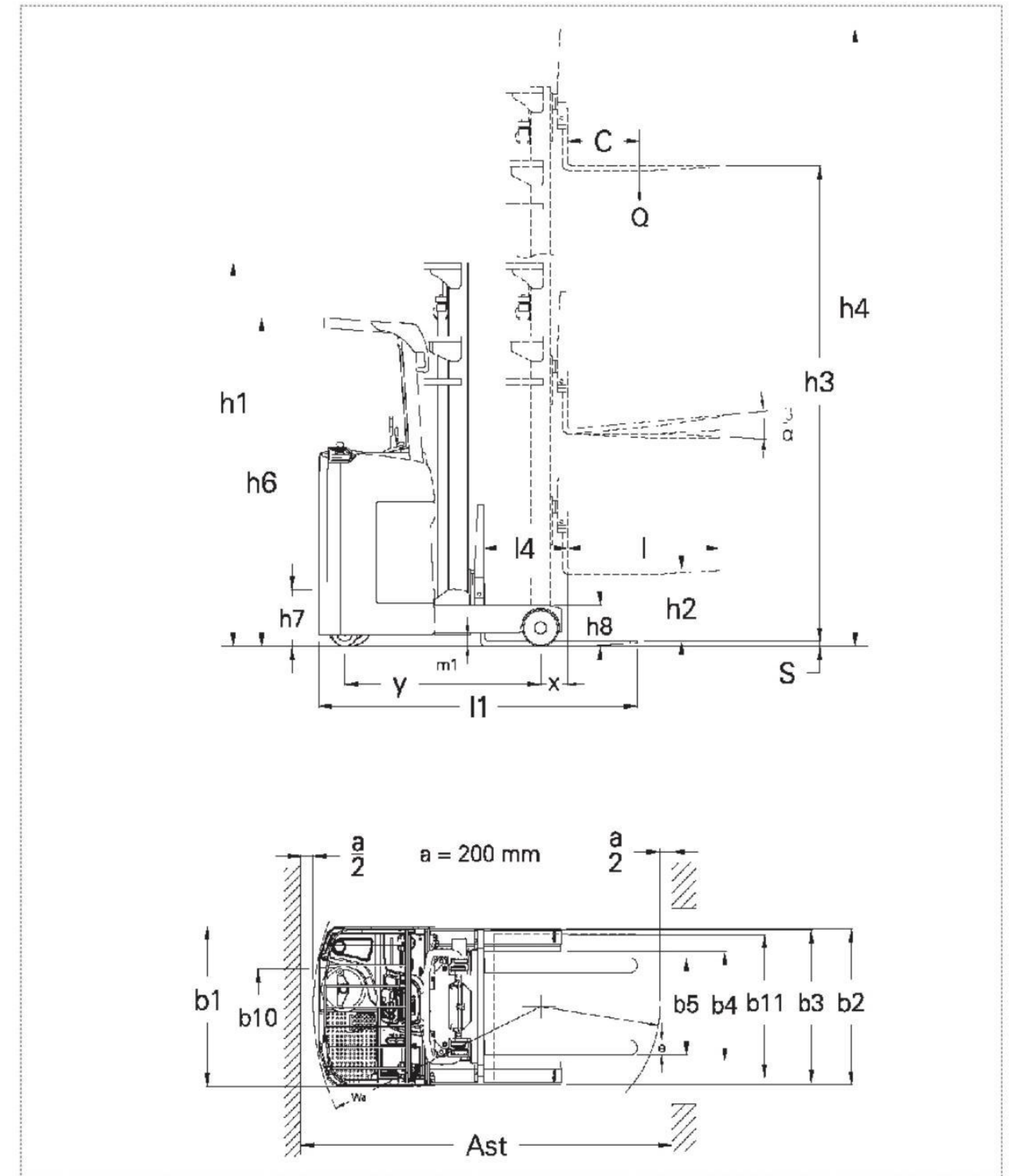

标准/Standard					
1.2 型号 Model		MF15	MF15SQ	MF20	MF20SQ
1.3 动力类型 Power type		蓄电池 Battery	蓄电池 Battery	蓄电池 Battery	蓄电池 Battery
1.4 驾驶方式 Driving mode		站驾式 Station driving type	站驾式 Station driving type	站驾式 Station driving type	站驾式 Station driving type
1.5 额定载荷 Rated load	Q (kg)	1500	1500	2000	2000
1.6 载荷中心距 Load center distance	C (mm)	500	500	500	500
1.7 前悬距 Front suspension distance	x (mm)	180	180	180	180
1.8 轴距 Wheelbase	y (mm)	1345	1345	1545	1545
重量/Weight					
2.1 整车重量 (含电池) Vehicle weight (Containing battery)	kg	2450	2850	2750	2950
2.2 空载时的桥负荷, 驱动侧/承重侧 Bridge load at no load, drive side / load side	kg	1625/825	1900/950	/	/
2.3 满载时的桥负荷, 货叉前移, 驱动侧/承重侧 Full load bridge load, fork forward, drive side / load side	kg	660/3290	600/3750	/	/
2.4 满载时的桥负荷, 货叉收回, 驱动侧/承重侧 Bridge load with full load, fork retracted, drive side / load side	kg	1510/2440	1600/2750	/	/
轮胎/Tyre					
3.1 轮胎类型, 驱动侧/承重侧 Tire type, drive / load side		聚氨酯 PU	聚氨酯 PU	聚氨酯 PU	聚氨酯 PU
3.2 轮胎尺寸, 承重侧 Tire size, load side	mm	Φ 254×104	Φ 254×104	Φ 254×104	Φ 254×104
3.3 轮胎尺寸, 驱动侧 Tire size, drive side	mm	Φ 343×108	Φ 343×108	Φ 343×108	Φ 343×108
3.4 稳定轮尺寸 Size of stabilizing wheel	mm	Φ 180×76	Φ 180×76	Φ 180×76	Φ 180×76
3.5 车轮数量, 前/后(x=驱动轮) Number of wheels, front / rear (x=drive wheel)		2/1 x+2	2/1 x+2	2/1 x+2	2/1 x+2
3.6 轮距, 驱动侧 Track width, drive side	b10 (mm)	680	680	680	680
3.7 轮距, 承重侧 Track width, load side	b11 (mm)	964	1064	1064	1064
尺寸/Size					
4.1 货叉倾斜范围, 前/后 Fork tilt range, front / rear	α / β (°)	3/5	3/5	3/5	3/5
4.2 门架闭合高度 Gantry closing height	h1 (mm)	2080	2142	2082	2142
4.3 自由起升高度 Free lifting height	h2 (mm)	400	1542	80	1542
4.4 起升高度 Lifting height	h3 (mm)	3000	4500	3000	4500
4.5 起升时门架最大高度(含货架) Maximum height of gantry during lifting (including retaining rack)	h4 (mm)	3960	5460	3960	5460
4.6 护顶架高度 Height of roof support	h6 (mm)	2250	2250	2250	2250
4.7 站板高度 Station height	h7 (mm)	300	300	300	300
4.8 整车长度 Vehicle length	l1 (mm)	2258	2283	2299	2336
4.9 整车宽度 Vehicle width	b1/b2 (mm)	1090	1090 / 1170	1090/1170	1090/1170
4.10 货叉尺寸 Fork size	l/e/s (mm)	1070 / 100 / 35	1070 / 100 / 35	1070/122/40	1070/122/40
4.11 货架架宽度 Shelf width	b3 (mm)	1088	1088	1088	1088
4.12 货叉外间距 Fork outside distance	b5 (mm)	222 -650	222 -750	244-772	244-772
4.13 支腿内侧间距 Inner distance of Outigger	b4 (mm)	750	856	856	856
4.14 前移距离 fork rake	l4 (mm)	550	525	717	677
4.15 门架离地间隙 Clearance between gantry and ground	m1 (mm)	82	82	82	82
4.16 直角堆垛通道宽度(托盘1000x1200)500mm载荷中心 Right angle stacking channel width (tray 1000x1200)500mm load center	Ast (mm)	2663	2681	2746	2769
4.17 直角堆垛通道宽度(托盘800x1200) Right angle stacking channel width (tray 800x1200)600mm load center	Ast (mm)	2714	2737	2764	2796
4.18 转弯半径 Turning radius	Wa (mm)	1594	1594	1784	1784
性能/Performance					
5.1 行驶速度, 满/空载 Travel speed, full / empty	km / h	9/10	9/10	9/10	9/10
5.2 起升速度, 满/空载 Travel speed, full / empty	mm / s	240/400	200/350	220/380	180/330
5.3 下降速度, 满/空载 Descent speed, full / empty	mm / s	300/270	320/280	310/260	290/240
5.4 最大爬坡能力, 满/空载 Maximum climbing capacity, full / empty	%(tan θ)	≤10	≤10	≤10	≤10
5.5 制动方式 Braking mode		机械式 Mechanical	机械式 Mechanical	机械式 Mechanical	机械式 Mechanical
驱动/Drive					
6.1 驱动电机功率 Drive motor power	kw	4.5	4.5	4.5	4.5
6.2 起升电机功率 Power of lifting motor	kw	7.5	7.5	7.5	7.5
6.3 蓄电池, 电压/额定容量 Battery, voltage / rated capacity	V/Ah	48/300	48/300	48/300	48/300
6.4 电池重量 Battery weight	kg	500	500	500	500
6.5 转向系统 steering system		纯电转向 EPS	纯电转向 EPS	纯电转向 EPS	纯电转向 EPS
其它/Other					
7.1 电池更换方式 Battery replacement		侧拉式 Side pull type	侧拉式 Side pull type	侧拉式 Side pull type	侧拉式 Side pull type
7.2 锂电池选装, 电压/额定容量 Battery option, voltage / rated capacity	V/Ah	48/240	48/240	48/240	48/240

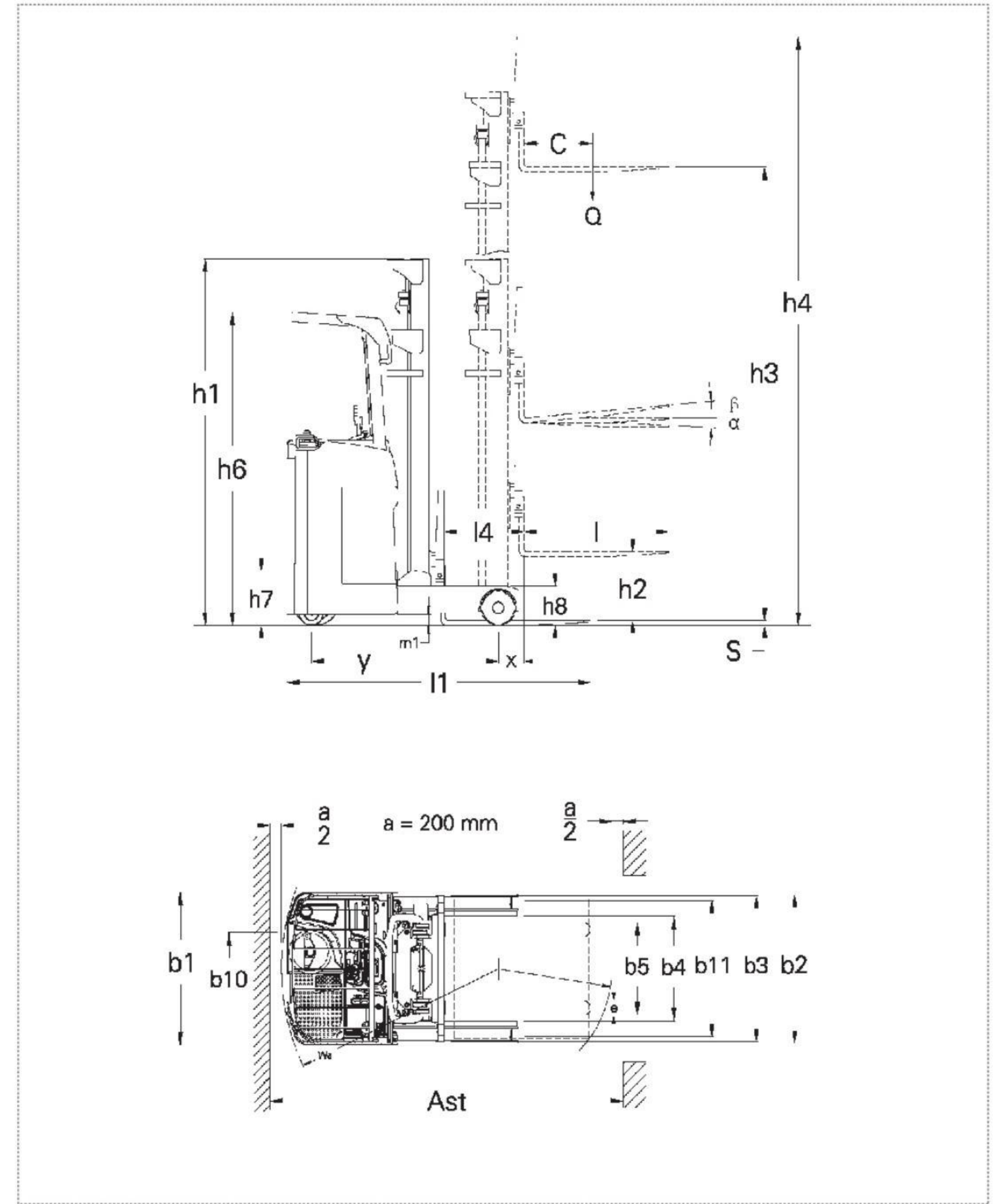

标准/Standard					
1.2 型号 Model		MF25	MF25SQ	MF30	MF30SQ
1.3 动力类型 Power type		蓄电池	蓄电池	蓄电池	蓄电池
1.4 驾驶方式 Driving mode		站驾式	站驾式	站驾式	站驾式
1.5 额定载荷 Rated load	Q (kg)	2500	2500	3000	3000
1.6 载荷中心距 Load center distance	C (mm)	500	500	500	500
1.7 前悬距 Front suspension distance	x (mm)	180	180	180	180
1.8 轴距 Wheelbase	y (mm)	1720	1720	1920	1920
重量/Weight					
2.1 整车重量 (含电池) Vehicle weight (Containing battery)	kg	3300	3580	3400	3680
2.2 空载时的桥负荷, 驱动侧/承重侧 Bridge load at no load, drive side / load side	kg	/	/	/	/
2.3 满载时桥负荷, 货叉前移, 驱动侧/承重侧 Full load bridge load, fork forward, drive side / load side	kg	/	/	/	/
2.4 满载时桥负荷, 货叉收回, 驱动侧/承重侧 Bridge load with full load, fork retracted, drive side / load side	kg	/	/	/	/
轮胎/Tyre					
3.1 轮胎类型, 驱动侧/承重侧 Tire type, drive / load side		聚氨酯 PU	聚氨酯 PU	聚氨酯 PU	聚氨酯 PU
3.2 轮胎尺寸, 承重侧 Tire size, load side	mm	Φ 267×135	Φ 267×135	Φ 267×135	Φ 267×135
3.3 轮胎尺寸, 驱动侧 Tire size, drive side	mm	Φ 380×165	Φ 380×165	Φ 380×165	Φ 380×165
3.4 稳定轮尺寸 Size of stabilizing wheel	mm	Φ 204×76	Φ 204×76	Φ 204×76	Φ 204×76
3.5 车轮数量, 前/后(x=驱动轮) Number of wheels, front/rear(x=drives wheel)		2/1 x+2	2/1 x+2	2/1 x+2	2/1 x+2
3.6 轮距, 驱动侧 Track width, drive side	b10 (mm)	725	725	725	725
3.7 轮距, 承重侧 Track width, load side	b11 (mm)	1135	1135	1135	1135
尺寸/Size					
4.1 货叉倾斜范围, 前/后 Fork tilt range, front/rear	α / β (°)	3/5	2/6	3/5	2/6
4.2 门架闭合高度 Gantry closing height	h1 (mm)	2082	2292	2082	2292
4.3 自由起升高度 Free lifting height	h2 (mm)	80	1550	80	1550
4.4 起升高度 Lifting height	h3 (mm)	3000	4500	3000	4500
4.5 起升时门架最大高度(含货架) Maximum height of gantry during lifting (including retaining rack)	h4 (mm)	3960	5460	4050	5550
4.6 护顶架高度 Height of roof support	h6 (mm)	2300	2300	2300	2300
4.7 站板高度 Station height	h7 (mm)	350	350	350	350
4.8 整车长度 Vehicle length	l1 (mm)	2387	2434	2487	2534
4.9 整车宽度 Vehicle width	b1/b2 (mm)	1190/1270	1190/1270	1190/1270	1190/1270
4.10 货叉尺寸 Fork size	l/e/s (mm)	1070/122/40	1070/122/40	1070/125/45	1070/125/45
4.11 货架架宽度 Shelf width	b3 (mm)	1088	1088	1148	1148
4.12 货叉外侧距 Fork outside distance	b5 (mm)	244-772	244-772	250-750	250-750
4.13 支腿内侧间距 Inner distance of Outrigger	b4 (mm)	892	892	892	892
4.14 前移距离 Fork rake	l4 (mm)	825	775	925	875
4.15 门架离地间隙 Clearance between gantry and ground	m1 (mm)	82	82	82	82
4.16 直角堆垛通道宽度(托盘1000x1200)500mm载荷中心 Right angle stacking channel width (tray 1000x1200)500mm load center	Ast (mm)	2894	2919	3045	3066
4.17 直角堆垛通道宽度(托盘800x1200) Right angle stacking channel width (tray 800x1200)600mm load center	Ast (mm)	2882	2921	3000	3037
4.18 转弯半径 Turning radius	Wa (mm)	1995	1995	2192	2192
性能/Performance					
5.1 行驶速度, 满/空载 Travel speed, full/empty	km/h	9/10	9/10	8/10	8/10
5.2 起升速度, 满/空载 Lifting speed, full/empty	mm/s	240/320	220/300	220/320	200/300
5.3 下降速度, 满/空载 Descent speed, full/empty	mm/s	340/290	310/260	340/290	310/260
5.4 最大爬坡能力, 满/空载 Maximum climbing capacity, full/empty	%(tan θ)	≤10	≤10	≤10	≤10
5.5 制动方式 Braking mode		机械式	机械式	机械式	机械式
驱动/Drive					
6.1 驱动电机功率 Drive motor power	kw	5.5	5.5	5.5	5.5
6.2 起升电机功率 Power of lifting motor	kw	8.6	8.6	8.6	8.6
6.3 蓄电池, 电压/额定容量 Battery, voltage / rated capacity	V/Ah	48/400	48/400	48/400	48/400
6.4 电池重量 Battery weight	kg	650	650	650	650
6.5 转向系统 steering system		纯电转向	纯电转向	纯电转向	纯电转向
其它/Other					
7.1 电池更换方式 Battery replacement		侧拉式	侧拉式	侧拉式	侧拉式
7.2 锂电池选装, 电压/额定容量 Battery option, voltage / rated capacity	V/Ah	48/320	48/320	48/320	48/320

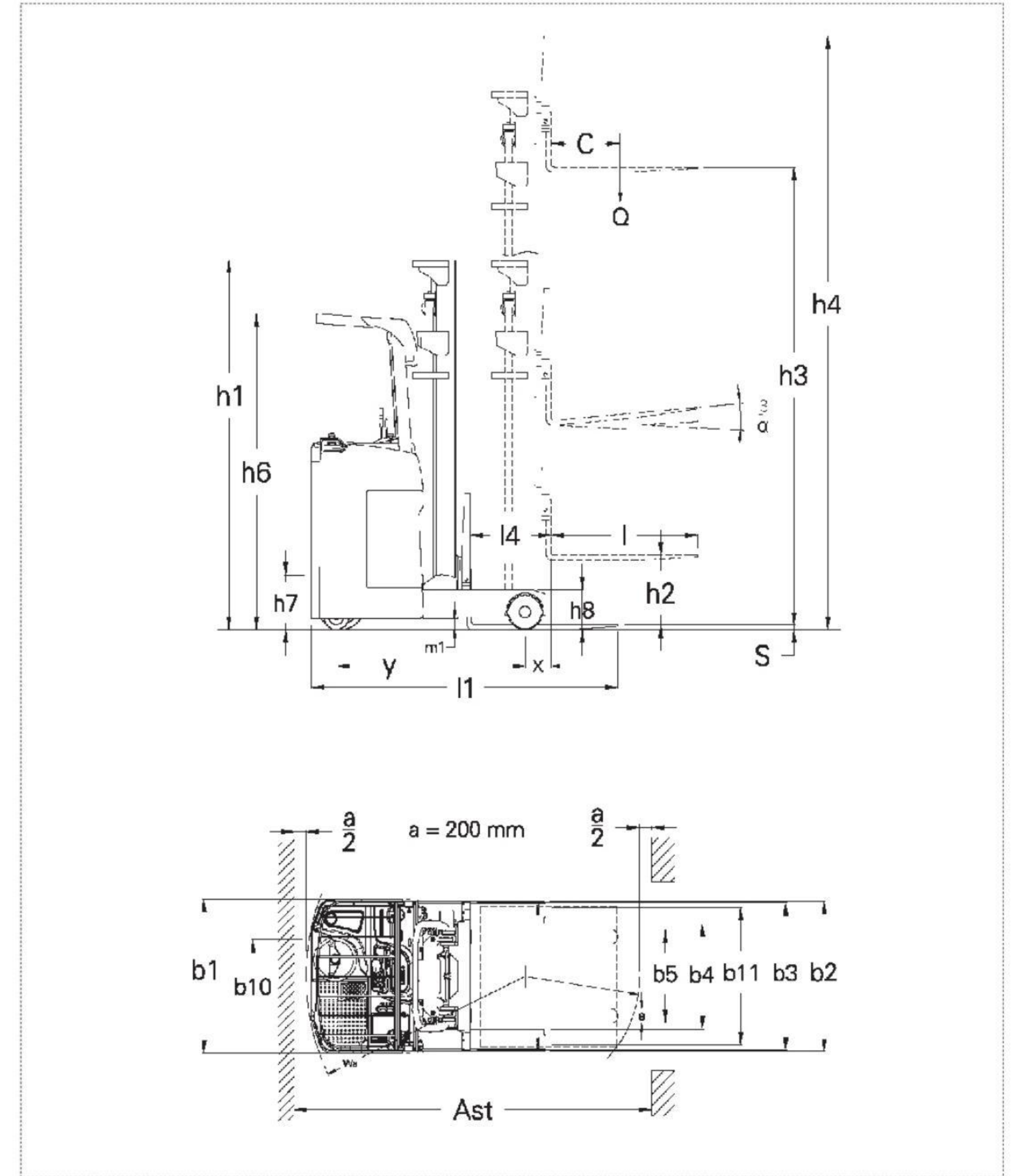

两节门架 Duplex Mast		MF12			
型号 Model	MF	12-30	12-35	12-40	12-45
提升高度 Lift height	h3(mm)	3000	3500	4000	4500
起升时门架最大高度(含挡货架) Height-Mast Extended w/ Load-Backrest	h4(mm)	3960	4460	4960	5460
闭合门架高度 Height--Mast Lowered	h1(mm)	2080	2330	2630	2880

三节全自由门架 Triplex full free Mast		MF12			
型号 Model	MF	12SQ-45	12SQ-50	12SQ-55	12SQ-60
提升高度 Lift height	h3(mm)	4500	5000	5500	6000
起升时门架最大高度(含挡货架) Height-Mast Extended w/ Load-Backrest	h4(mm)	5455	5955	6455	6955
闭合门架高度 Height--Mast Lowered	h1(mm)	2080	2247	2413	2580
自由起升高度 Height-Free Lift	h2(mm)	1480	1647	1813	1980

两节门架 Duplex Mast		MF15				MF15D			
型号 Model	MF	15-30	15-35	15-40	15-45	15D-30	15D-35	15D-40	15D-45
提升高度 Lift height	h3(mm)	3000	3500	4000	4500	3000	3500	4000	4500
起升时门架最大高度(含挡货架) Height-Mast Extended w/ Load-Backrest	h4(mm)	3960	4460	4960	5460	3960	4460	4960	5460
闭合门架高度 Height--Mast Lowered	h1(mm)	2082	2332	2632	2882	2080	2330	2630	2880
自由起升高度 Height-Free Lift	h2(mm)	400	400	400	400	0	0	0	0

三节全自由门架 Triplex full free Mast		MF15D	
型号 Model	MF	15DSQ-45	15DSQ-50
提升高度 Lift height	h3(mm)	4500	5000
起升时门架最大高度(含挡货架) Height-Mast Extended w/ Load-Backrest	h4(mm)	5455	5955
闭合门架高度 Height--Mast Lowered	h1(mm)	2080	2247
自由起升高度 Height-Free Lift	h2(mm)	1480	1647

三节全自由门架 Triplex full free Mast		MF15								
型号 Model	MF	15SQ-45	15SQ-50	15SQ-55	15SQ-60	15SQ-65	15SQ-70	15SQ-72	15SQ-75	
提升高度 Lift height	h3(mm)	4500	5000	5500	6000	6500	7000	7200	7500	
起升时门架最大高度(含挡货架) Height-Mast Extended w/ Load-Backrest	h4(mm)	5460	5960	6460	6960	7460	7960	8160	8460	
闭合门架高度 Height--Mast Lowered	h1(mm)	2142	2309	2475	2642	2809	2975	3042	3142	
自由起升高度 Height-Free Lift	h2(mm)	1542	1709	1875	2042	2209	2375	2442	2542	

两节门架 Duplex Mast		MF20				MF25			
型号 Model	MF	20-30	20-35	20-40	20-45	25-30	25-35	25-40	25-45
提升高度 Lift height	h3(mm)	3000	3500	4000	4500	3000	3500	4000	4500
起升时门架最大高度(含挡货架) Height-Mast Extended w/ Load-Backrest	h4(mm)	3960	4460	4960	5460	3960	4460	4960	5460
闭合门架高度 Height--Mast Lowered	h1(mm)	2082	2332	2632	2882	2082	2332	2632	2882
自由起升高度 Height-Free Lift	h2(mm)	80	80	80	80	80	80	80	80

三节全自由门架 Triplex full free Mast		MF20								
型号 Model	MF	20SQ-45	20SQ-50	20SQ-55	20SQ-60	20SQ-65	20SQ-70	20SQ-72	20SQ-75	
提升高度 Lift height	h3(mm)	4500	5000	5500	6000	6500	7000	7200	7500	
起升时门架最大高度(含挡货架) Height-Mast Extended w/ Load-Backrest	h4(mm)	5460	5960	6460	6960	7460	7960	8160	8460	
闭合门架高度 Height--Mast Lowered	h1(mm)	2142	2309	2475	2642	2809	2975	3042	3142	
自由起升高度 Height-Free Lift	h2(mm)	1542	1709	1875	2042	2209	2375	2442	2542	

三节全自由门架 Triplex full free Mast		MF25								
型号 Model	MF	25SQ-45	25SQ-50	25SQ-55	25SQ-60	25SQ-65	25SQ-70	25SQ-72	25SQ-75	25SQ-80
提升高度 Lift height	h3(mm)	4500	5000	5500	6000	6500	7000	7200	7500	8000
起升时门架最大高度(含挡货架) Height-Mast Extended w/ Load-Backrest	h4(mm)	5460	5960	6460	6960	7460	7960	8160	8460	8960
闭合门架高度 Height--Mast Lowered	h1(mm)	2292	2459	2625	2792	2959	3125	3192	3292	3559
自由起升高度 Height-Free Lift	h2(mm)	1550	1716	1884	2050	2216	2384	2450	2550	2816

两节门架 Duplex Mast		MF30			
型号 Model	MF	30-30	30-35	30-40	30-45
提升高度 Lift height	h3(mm)	3000	3500	4000	4500
起升时门架最大高度(含挡货架) Height-Mast Extended w/ Load-Backrest	h4(mm)	4050	4550	5050	5550
闭合门架高度 Height--Mast Lowered	h1(mm)	2082	2332	2632	2882
自由起升高度 Height-Free Lift	h2(mm)	80	80	80	80

三节全自由门架 Triplex full free Mast		MF30								
型号 Model	MF	30SQ-45	30SQ-50	30SQ-55	30SQ-60	30SQ-65	30SQ-70	30SQ-72	30SQ-75	30SQ-80
提升高度 Lift height	h3(mm)	4500	5000	5500	6000	6500	7000	7200	7500	8000
起升时门架最大高度(含挡货架) Height-Mast Extended w/ Load-Backrest	h4(mm)	5550	6050	6550	7050	7550	8050	8250	8550	9050
闭合门架高度 Height--Mast Lowered	h1(mm)	2292	2459	2625	2792	2959	3125	3192	3292	3559
自由起升高度 Height-Free Lift	h2(mm)	1550	1716	1884	2050	2216	2384	2450	2550	2816

